

# SlabDrain - H100KS-6 Stainless Steel Edge Rail Channel System

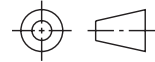

**H100KS-6 Neutral Channel**  
part #141804

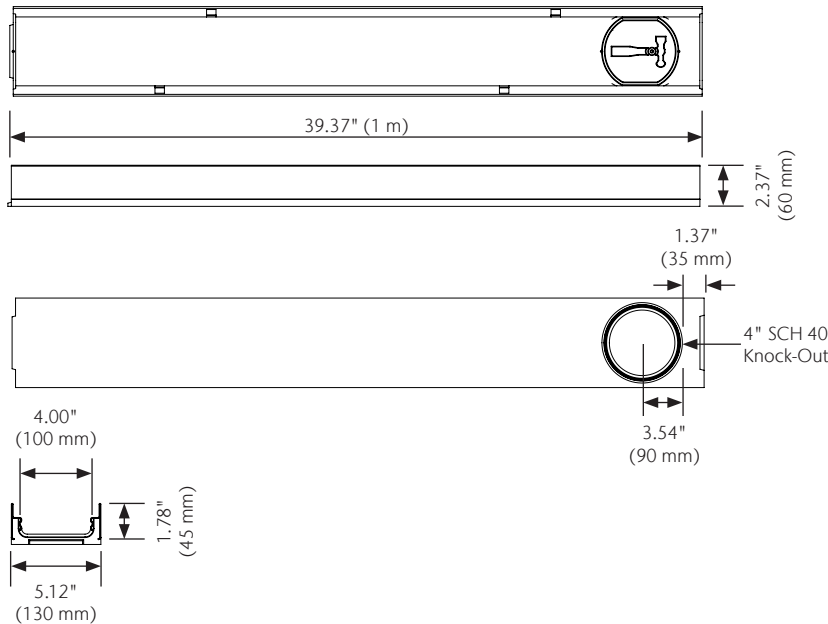

**H100KS-6 Closing End Cap**  
part #296097

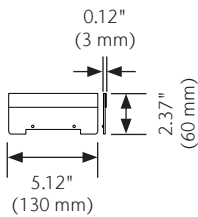

Outlet Flow Rates	Outlet Size (SCH 40)	Invert Depth in (mm)	GPM	CFS
H100KS-6 Neutral Channel - 39.37" (1 m)	4" round	1.78 (45)	71.8	0.16

**Notes:** These are the pipe flow rates at the specified outlet, NOT channel flow rates.

H100KS-6 Parts	Part #	Invert Depth in (mm)	Weight lbs
H100KS-6 Neutral Channel - 39.37" (1 m)	<b>141804</b>	1.78 (45)	7.6
H100KS-6 Closing Cap	<b>296097</b>	1.78 (45)	0.1

**Notes:**

1. Add nominal 0.6" (15 mm) to invert depth for overall channel depth
2. Preformed 4" SCH 40 knock-out cast on underside of each channel
3. Use grate removal tool to remove grates (Part # 01318)

**Specifications**

**General**

The surface drainage system shall be ACO Drain SlabDrain H100KS-6 complete with gratings secured with DrainLok as manufactured by ACO, Inc. or equal approved.

**Materials**

The trench system bodies shall be manufactured from polyester polymer concrete with minimum properties as follows:

- Compressive strength: 13,000 psi
- Flexural strength: 3,100 psi
- Water absorption: 0.07%
- Frost proof
- Salt proof
- Dilute acid and alkali resistant

The nominal clear opening shall be 4.00" (100 mm) with overall width of 5.12" (130 mm). Pre-cast units shall be manufactured with neutral invert and have a wall thickness of at least 0.5" (13 mm). Each unit will feature a male to female interconnecting end profile. The stainless steel edge rail will be integrally cast in by the manufacturer to ensure maximum homogeneity between polymer concrete body and edge rail. Each edge rail shall be at least 1/8" (3 mm) thick.

**Grates**

Grates should be specified. See separate ACO Spec Info grate sheets for details. After removal of grates, there shall be uninterrupted access to the trench to aid maintenance.

**Installation**

The trench drain system shall be installed in accordance with the manufacturer's installation instructions and recommendations.

ACO Specification Information

**ACO, Inc.**

West Sales Office  
825 W. Beechcraft Street  
Casa Grande, AZ 85122  
Tel: (520) 421-9988  
Toll-Free: (888) 490-9552  
Fax: (520) 421-9899

Northeast Sales Office  
9470 Pinecone Drive  
Mentor, OH 44060  
Tel: (440) 639-7230  
Toll-Free: (800) 543-4764  
Fax: (440) 639-7235

Southeast Sales Office  
4211 Pleasant Road  
Fort Mill, SC 29708  
Toll-Free: (800) 543-4764  
Fax: (803) 802-1063

info@acousa.com  
www.acousa.com



© May 2020 ACO, Inc.

All reasonable care has been taken in compiling the information in this document. All recommendations and suggestions on the use of ACO products are made without guarantee since the conditions of use are beyond the control of the company. It is the customer's responsibility to ensure that each product is fit for its intended purpose and that the actual conditions of use are suitable. ACO, Inc. reserves the right to change products and specifications without notice.

ACO. creating the future of drainage

